

240V ELECTRIC OIL PUMPS

INSTRUCTION MANUAL



EOP25L



EOP50L

INTRODUCTION

The Macnaught Electric 240V Oil Pumps are designed to reliably transfer oil.

The pumps are supplied with a 2m long power cord and plug.



CAUTION

Important Information

PLEASE READ THIS SAFETY INFORMATION CAREFULLY BEFORE USE.

Read and retain this instruction manual to assist you in the operation and maintenance of this product.

'CAUTIONS' are listed throughout this manual to advise of actions which may cause damage to your equipment.

Description

The pump is made up of the following parts:

PUMP - volumetric self-priming rotary vane electric pump fitted with a bypass valve.

MOTOR - Single-phase asynchronous motor, 2-pole, closed (protection class IP55 in compliance with Standard EN60034-5-86), self-ventilating, directly flanged to the pump body

Safety Information

- * Macnaught recommends the use of PPE equipment such as safety glasses, protective gloves, safety shoes etc before handling or using this product.
- * Do not modify or alter this product any way
- * Ensure that any fluid spillage is cleaned up immediately to prevent slipping or injury.
- * Only use this product in a safe environment, away from heat, fire or explosive atmospheres etc
- * Only use genuine Macnaught replacement parts when repairing this product
- * Only use this pump with clean fluid

Note: Do not use on waste oil

Pump Legend Plate Information

Batch of
Model
Description
Technical specifications
Weight

OPERATING CONDITIONS

Temperature	Relative humidity
min. +10°C / max. +60°C	(*) max. 90%

(*) Caution! The temperature limits show refer to the components making up the pump and should be respected to prevent any damages or malfunction from occurring.

Power Supply

Depending on the model, the pump must be powered by the single-phase or three-phase AC line whose values are given in the table in section 2.3 - Technical specifications. Powering the pump with values outside these limits can damage the electrical components or cause them to malfunction. The maximum power supply variations allowed are: Voltage: +/- 5% of the nominal value Frequency: +/- 2% of the nominal value
The motors are designed the operating cycle of 30min on / 30 min off

Allowed Fluids / Forbidden Fluids

ALLOWED FLUIDS - OIL with viscosity up from 50 cSt up to 500 cSt (Minimum flash point (MF): 55 °C)

FORBIDDEN FLUIDS - Petrol, flammable liquids (MF <55°C), solvents, liquids with > 500 cSt viscosity food liquids, corrosive chemicals, water

UNPACKING NEW PUMP

Carefully open the box, remove the pump and place it on the floor or on a stable surface.

Check pump and any signs of damage.

Note: any damage found on unpacking product must be reported immediately.

INSTALLATION

1. Ensure the pump is not damaged.
2. Remove any remaining packaging material from the product (e.g. protective caps) and carefully clean the suction and discharge outlets.
3. Install the pump in either horizontal or vertical position.
4. Place pump in a sheltered location away from rain and weather events.
5. Position and fix the pump with screws that are suitably sized for the holes on the motor flange.

Note: The best performance in terms of noise and vibration reduction is achieved by placing 4 vibration dampers of suitable height between the pump and the base.



CAUTION

The motors are not explosion-proof. They must not be installed in areas with flammable vapours or open flames

6. Before connecting the pump, make sure the tank, fittings and pipes used are clean and free from waste or processing residues.
7. Before connecting the discharge pipe to the pump, we recommend partially filling the pump body with diesel fuel to lubricate and facilitate the priming procedure.



CAUTION

Do not use tapered fittings as overtightening damage the pump outlets.
Do not over tighten connections



WARNING

The pump is **not** equipped with an internal suction filter, it is necessary to use the use of a suction filter with a maximum mesh of 800 µm to prevent foreign bodies from damaging the pump.

ALL MODELS	Suction	Discharge
Pump inlet connection thread	1" G - BSP	1" G - BSP
Recommended minimum internal diameters	ø25 mm	ø19 mm
Recommended rated pressure	10 Bar	30 Bar
Pipe suitable for operation under negative pressure	•	

Suction line



CAUTION

Only use this pump with NEW fluid.

If pumping Diesel, a mesh strainer MUST be installed in the suction line

These self-priming pumps are capable of sucking up the liquid through a 1" I/D diameter suction hose to a maximum height of 2 meters.

The correct priming time required to be carried out can be influenced by the presence of a delivery gun, which prevents the normal evacuation of air from the tube.

It is always advisable to carry out first priming operation without a gun

When the system is running, the pump can work with a pressure restriction in the suction port up to 0.7 Bar, after which cavitation can begin, with a consequent decrease in the flow rate and an increase in noise.

To avoid this phenomenon, it is important to ensure no restriction in the suction line.

Only use suction filters with a large section and foot valves with the minimum possible resistance, the filter should be kept clean to avoid damage.

Delivery line

The delivery line should be at least 3/4" I/D.

Note: The incorrect combination of pipe length, diameter and accessories can create excess pressure loss which can affect pump performance.

To prevent this, the system resistance has to be reduced using shorter pipes and/ or with a larger diameter and line and using accessories with less resistance (e.g. an automatic nozzle for greater flow rates).



WARNING

ELECTRICAL CONNECTION

The pumps are supplied complete with a 2 m long cable. and plug.

Any electrical repairs must be carried out by a licensed electrician.

Single-phase motors are equipped with phase capacitor and bipolar switch.

ELECTRICAL MAINTENANCE



WARNING

For installation and electrical maintenance of the pump, please follow these instructions:

During the installation and maintenance of the pump, turn off and disconnect the plug from the power source.

Use only cables with the minimum section, rated voltages and type of laying appropriate to the characteristics of the system
always connect the pump earth terminal to the network earth

The pumps are supplied complete with a 2 m long cable. and plug.

Any electrical installation or repairs must be carried out by a licenced electrician.

Single-phase motors are equipped with phase capacitor and bipolar switch.



CAUTION

The pumps are supplied without safety equipment such as fuses, motor protectors, systems against accidental restarting after periods of power failure.

The sole function of the pump switch function is for starting and stopping the pump.

OPERATION

Before starting the pump, check that all pipes and components in the system are in good condition and are properly sealed, and the nozzle is closed,



WARNING

Do not leave pump unattended during use
Do not start the pump before connecting the suction and delivery pipes.
Do not start or stop the pump by inserting or removing the plug.
The use of PPE equipment such as glasses and gloves is mandatory.

The motor is protected Single-phase with a motor protector which protects against accidental restarting

In the event of a power failure, turn off the pump and unplug it before resetting it.

In extreme conditions for the pump can cause the temperature rise of the motor and its consequent stop by the thermal protection. Turn off the pump switch and wait for it to cool down before resuming the intended use. The thermal protection switches off automatically when the engine has cooled down sufficiently.



CAUTION

When first priming the pump air will need to be purged from the lines.

To purge the lines, make sure the nozzle or the discharge outlet is open. If an automatic nozzle is installed on the discharge line, it is recommended to temporarily remove during first start-up.

DAILY USE

Before use, check pump hoses and fittings for any signs of wear or damage and replace as required.

Before turning pump on, make sure the nozzle or valve is closed.

The pump can remain in by pass (internal circulation) for a maximum of 1-2 minutes

With the pump in bypass, open the nozzle or valve to start dispensing

When you have finished dispensing, close the valve or nozzle and switch the pump off.

MAINTENANCE



CAUTION

Make sure the pump is disconnected from the power supply before carrying out maintenance

The pump is designed to minimise routine maintenance. It is the operator's responsibility to assess the pumps condition and suitability for use.

Any electrical maintenance should be carried out by a licenced electrician.

WIRING DIAGRAM

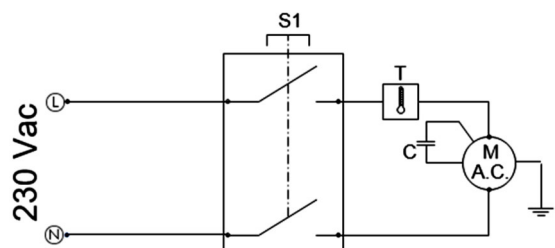

PARTS DIAGRAM

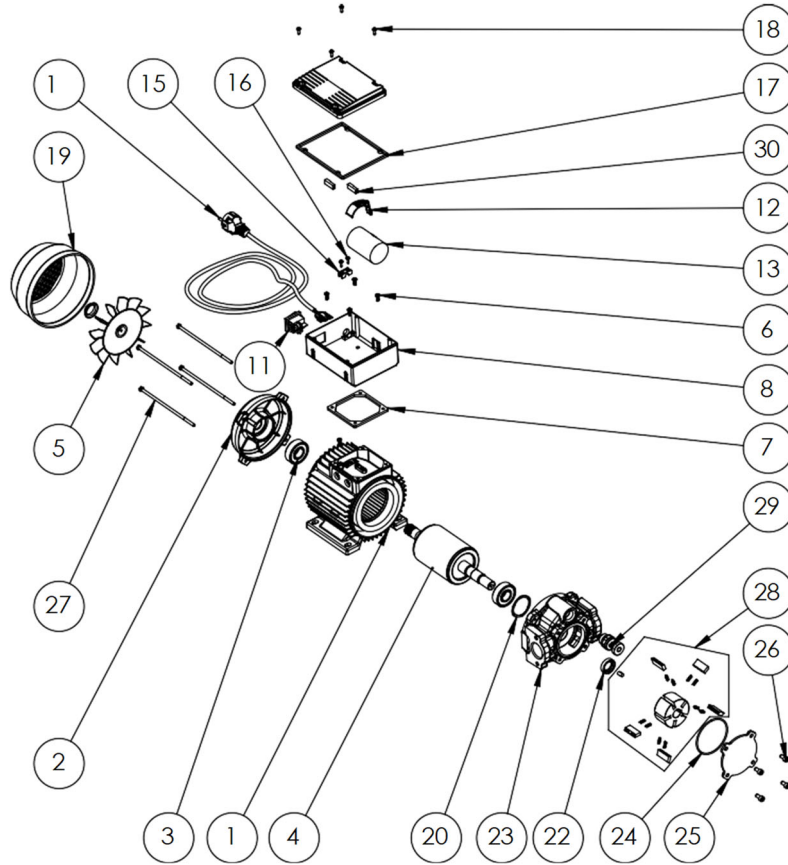

PARTS LIST

	CODE	DESCRIPTION	Q.ty		CODE	DESCRIPTION	Q.ty
1	ME048	STATOR MEC80	1	16	80801215000	SCREW TC Ø3,5x13 ISO 7049	2
2	ME049	SHIELD MEC 80	1	17	PA041	CAPACITOR BOX SEAL	1
3	101001880000	BALL BEARING 6204 2RS	2	18	VT068	SCREW TC Ø3,5x16 UNI 6954	4
4	ME044	ROTOR MEC 80	1	19	PA049	FAN COVER M80	1
5	PA048	FAN MEC80 + RING	1	20	VT069	COMPENSATION RING LMKAS 47B	1
6	VT048	SCREW TC 3.5X12 UNI8112	5	22	OR050	MOTOR SHAFT SEAL 20X30X7 GBP	1
7	PA045	SEAL GFV80	1	23	CP014	OIL-PRESS 25 BODY PUMP	1
8	PA044	CAPACITOR BOX M80	1	24	OR052	O-RING 3287 NBR 72,7x2,62 CHAMBER	1
9	PA047	CABLE GLAND RUBBER PG16	1	25	OP001	OIL-PRESS PLATE	1
10	PA046	CABLE GLAND RING NUT PG16	1	26	13001018#	SCREW T.C.E.I. M6X12 UNI 5931ZNB	4
11	EL013	BLUE SWITCH 22X30	1	27	VT067	TIE ROD M5X160	4
12	PA042	CAPACITOR LOCK	1	28	OP006	ROTOR KIT	1
13	PA035	CAPACITOR 30µF	1	29	OP004	BY-PASS VALVE OIL-PRESS 25	1
14	190200000000	SHUKO CABLE 230V	1	30	190110000000	6.3 FASTON COVER	2
15	PA043	CABLE LOCK	1				

PARTS DIAGRAM

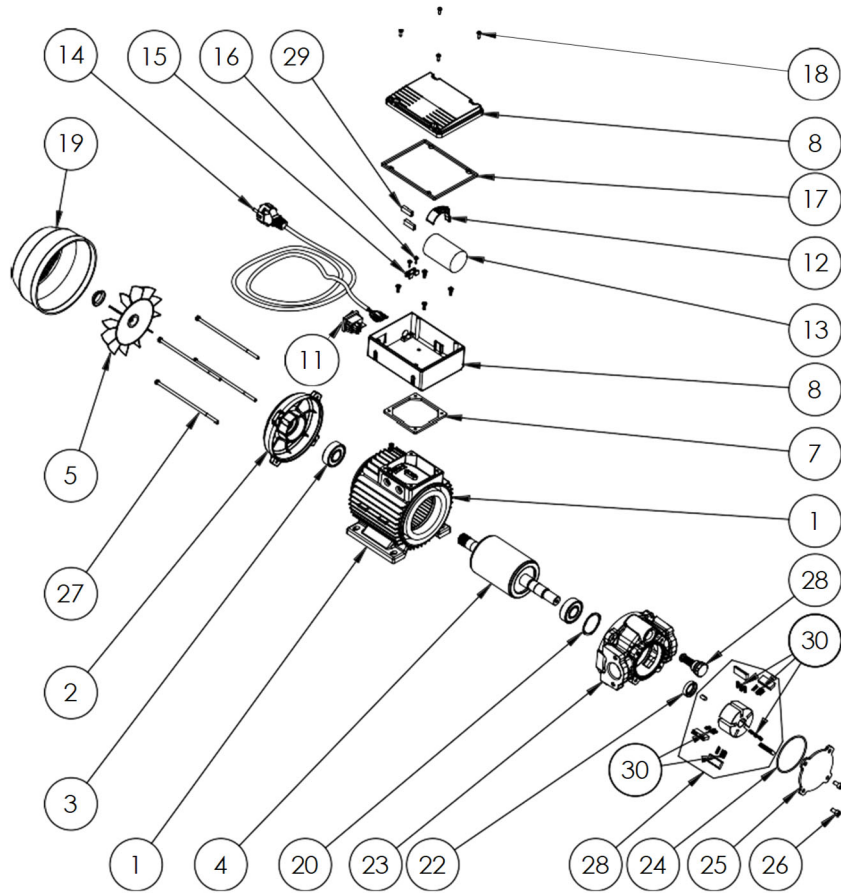

PARTS LIST

CODE	DESCRIPTION	Q.ty	CODE	DESCRIPTION	Q.ty	
1	ME048	WOUND STATOR M80	16	80801215000	SCREW TC Ø3,5x13 ISO 7049	2
2	ME049	MEC80 SHIELD	17	PA041	CAPACITOR BOX SEAL	1
3	101001880000	BALL BEARING 6204 2RS	18	VT068	SCREW TC Ø3,5x16 UNI 6954	4
4	ME044	ROTOR M80	19	PA049	FAN COVER M80	1
5	PA048	FAN MEC80 + RING	20	VT069	COMPENSATION RING LMKAS 47B	1
6	VT048	SCREW TC 3,5X12 UNI8112	22	OR050	MOTOR SHAFT SEAL 20X30X7 GBP VITON	1
7	PA045	SEAL GFV80	23	CP015	OIL-PRESS 50 BODY PUMP	1
8	PA044	CAPACITOR BOX M80	24	OR052	O-RING 3287 NBR 72,7x2,62 CHAMBER	1
9	PA047	CABLE GLAND RUBBER PG16	25	OP001	OIL-PRESS PLATE	1
10	PA046	CABLE GLAND RING NUT PG16	26	13001018	# SCREW T.C.E.I. M6X12 UNI 5931ZNB	4
11	EL013	BLUE SWITCH 22X30	27	VT067	TIE ROD M5X160	4
12	PA042	CAPACITOR LOCK	28	OP005	BY-BASS	1
13	PA035	CAPACITOR 30µF	29	190110000000	6.3 FASTON COVER	2
14	190200000000	SHUKO CABLE 230V	30	SP008	VANE SPRING	5
15	PA043	CABLE LOCK	31	OP006	ROTORKIT: ROTOR+VANES+SPRINGS+PIN	1

TROUBLESHOOTING GUIDE

PROBLEM	POSSIBLE CAUSE	CORRECTIVE ACTION
THE PUMP DOES NOT START UP	Power failure	Check the electrical connections and the safety devices
	The circuit breaker has tripped	Use the electric pump in the recommended operating conditions and according to its intended use (chap. 2 - chap. 5)
	Impeller blocked	Make sure there are no obstructions in the pump body or along the suction and discharge lines
	Defective motor	Contact the dealer (fault code M1)
PUMP IS VERY NOISY	Cavitation	Reduce the negative suction pressure
		Make sure there are no leaks or restrictions on the suction part (recommended pipes chap. 5.2)
	Air in the hydraulic circuit	Make sure there are no suction leaks Dispense to bleed the air from the circuit
LIQUID LEAK	Clamps loosened	Make sure all clamps are properly tightened
	Gaskets worn	Replace the worn gaskets
	Non-compatible liquids used	Check compatibility of the fluid used (chap. 3.3)
	Shaft seal ring dirty or damaged	Contact the dealer (fault code A1)

PROBLEM	POSSIBLE CAUSE	CORRECTIVE ACTION
LOW OR NO FLOW RATE	Low level of liquid in the tank	Fill the tank
	Filter dirty or clogged	Clean or replace the filter
	Foot valve dirty or clogged	Clean or replace the foot valve
	Pipe or dispensing nozzle damaged	Replace the damaged components
	Excessive negative pressure to the suction line	Make sure there are no leaks or restrictions on the suction part (recommended pipes chap. 5.2)
	High pressure drops in the circuit	Change the hydraulic discharge configuration
	Bypass valve open or blocked	Check the condition of the valve and clean or replace it if necessary
	Vanes blocked	Check and clean the vanes and their housings
	Excessive wear of the vanes or impeller	Replace the worn components
	Leaks from the gaskets	Make sure the gaskets are properly tightened and not worn
	Incorrect power supply voltage	Power the pump as specified on the rating plate
	Operating temperature too low	At low temperature, the viscosity of the oils increases in addition to the maximum allowed limit, use the pump in the temperature and viscosity range indicated in the manual.
	Defective motor	Contact the dealer (fault code M2)

OVERALL DIMENSIONS

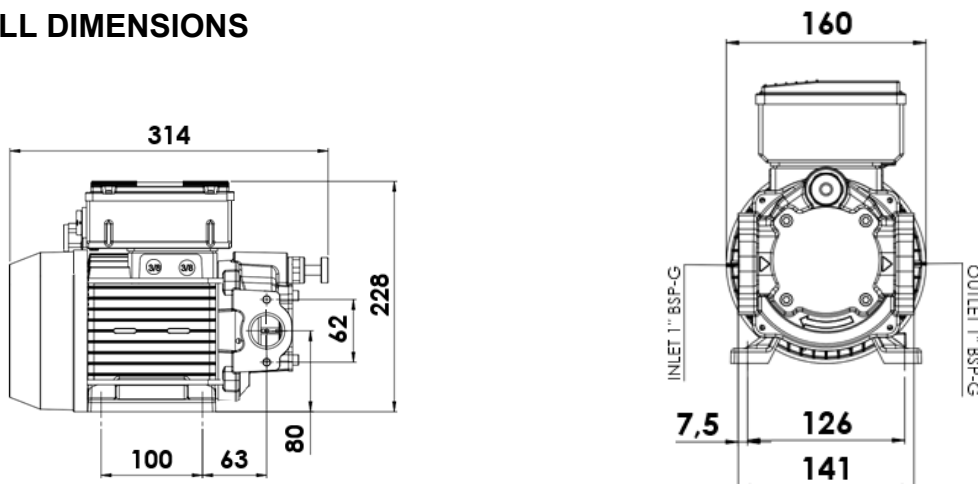

SPECIFICATIONS

Oil Pumps

SPECIFICATION	EOP25	EOP50
Voltage AC (V,Hz)	230,50/60	230,50/60
Power (W)	828 / 690	1081 / 1150
Current (A)	4,6 / 4,7	7 / 8,5
Motor Protection	IP55	IP55
On/Off Switch	Yes	Yes
Cable (m)	2	2
Duty Cycle	30 minute	30 minute
Nominal Flow rate (l/min)	25	50
Max Pressure (bar/psi)	7.5 / 108.8	7.5 / 108.8
Internal By-Pass	Adjustable	Fixed
Dry Suction Height (m)	2	2
Filter	external (not included)	external (not included)
Inlet / Outlet	1"(F) / 1"(F)	1"(F) / 1"(F)
Pump Body Material	Cast Iron	Cast Iron
Impeller Material	Sintered Steel	Sintered Steel
Vane Material	POM	POM
Shaft Seal Material	Viton	Viton
Gasket Material	NBR	NBR
Min/Max Temp (deg C)	-10 deg c / +60 deg c C	-10 deg c / +60 deg c C
Maximum Viscosity (cSt) at 40 degC	500	500
Allowed Fluids	Diesel / oil	Diesel / oil
Forbidden fluids	Gas, Alcohol, Petrol, Water	Gas, Alcohol, Petrol, Water
Noise at 1m (dB)	Les than 75 dB	Les than 75 dB
Net Weight (kg)	15.5	15.5



macnaught

Head Office - Australia
Macnaught Pty Limited
 ABN 66 000 075 785

41-49 Henderson St
 Turella, NSW, 2005
 Sydney, Australia.

T: +61 2 9567 0401
F: +61 2 9597 7773
W: www.macnaught.com.au

Macnaught USA Inc
(North & South America)
 614 South Ware Blvd. Tampa,
 Florida, 33619 United States.

T: +1813 628 5506
F: +1813 628 5506
E: info@macnaught.com
W: www.macnaughtusa.com

WEEE Directive - Waste Electrical and Electronic Equipment

The WEEE Directive requires the recycling of waste electrical and electronic equipment in the European Union.

Whilst the WEEE Directive does not apply to some of Macnaught's products, we support its policy and ask you to be aware of how to dispose of this product.

The crossed out wheelee bin symbol illustrated and found on our products signifies that this product should not be disposed of in general waste or landfill.

Please contact your local dealer national distributor or Macnaught Technical Services for information on product disposal.



Note:

This product should be disposed of according to all applicable local and national government environment regulations and guidelines.



For Warranty Terms and Conditions see macnaught.com.au
For a list of Australian Service Centres see macnaught.com.au

